

Shaft Support SK

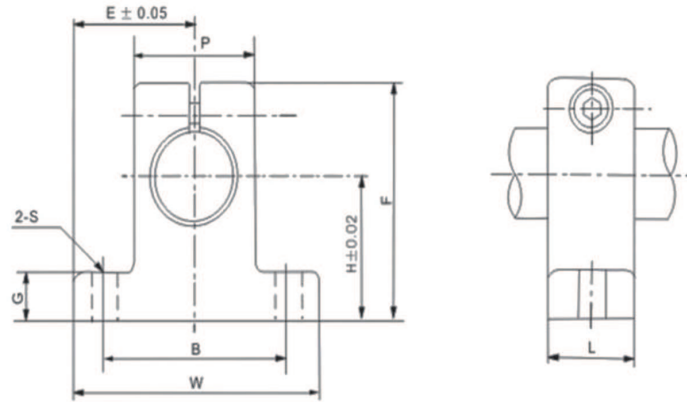

MODEL	SHAFT DIAMETER	MAIN DIMENSIONS									DESIGNATION OF CLAMPING BOLT	DESIGNATION OF MOUNTING BOLT	WEIGHT [Kg]
		H	E	W	L	F	G	P	B	S			
SK3	3	20	21	42	14	32.8	6	18	32	5.5	M4	M5	0.024
SK4	4	20	21	42	14	32.8	6	18	32	5.5	M4	M5	0.024
SK5	5	20	21	42	14	32.8	6	18	32	5.5	M4	M5	0.024
SK6	6	20	21	42	14	32.8	6	18	32	5.5	M4	M5	0.024
SK8	8	20	21	42	14	32.8	6	18	32	5.5	M4	M5	0.024
SK10	10	20	21	42	14	32.8	6	18	32	5.5	M4	M5	0.024
SK12	12	23	21	42	14	37.5	6	20	32	5.5	M4	M5	0.03
SK13	13	23	21	42	14	37.5	6	20	32	5.5	M4	M5	0.03
SK16	16	27	24	48	16	44	8	25	38	5.5	M4	M5	0.04
SK20	20	31	30	60	20	51	10	30	45	6.5	M5	M6	0.07
SK25	25	35	35	70	24	60	12	38	56	6.6	M6	M6	0.13
SK30	30	42	42	84	28	70	12	44	64	9	M6	M8	0.18
SK35	35	50	49	98	32	82	15	50	74	11	M8	M10	0.27
SK40	40	60	57	114	36	96	15	60	90	11	M8	M10	0.42
SK50	50	70	63	126	40	120	18	74	100	14	M12	M12	0.75